



Fluid Power Products, Inc.

302 Turnpike Road, Box 407, Southborough, MA 01772 - U.S.A



FLUID POWER PRODUCTS, INC.
OEM COMPONENT SOURCE AND SYSTEMS
DESIGN SPECIALISTS FOR 50 YEARS

Fluid Power Products Engineering Team is ready to assist your company with its hydraulic requirements. Fluid Power Products' experienced engineering staff will work with your designers to develop cost effective solutions. Fluid Power Products has over thirty five years of design experience in the application, selection and manufacture of standard and special hydraulic components, hydraulic systems and integrated hydraulic manifolds.



Flex Power Pack by...
Fluid Power Products, Inc.



Areas of Design Specialization Include:

- Custom-designed, integrated-circuit manifolds featuring SUN Hydraulics' floating cartridge valve technology with Unigraphics 3D CAD modeling
- System design and component selection
- Hydraulic Servo and Proportional Control Systems
- Hydraulic Power Units in fixed, variable and multiple pump types
- Miniature Hydraulic Systems
- Pump Applications and Hydrostatic Drives
- Heat Transfer systems utilizing shell & tube type coolers and air to liquid radiators



Fluid Power Products, Inc

302 Turnpike Road	4420 Independence Court
Southborough, MA 01772-0408	Sarasota FL 34234
(508) 481-8881	Phone: (941) 360-3311
(508) 485-4346	Fax: (941) 360-0294

Visit Our Web Site: www.fppinc.com
Or e-mail Us At: info@fppinc.com



Specializing In OEM Components & Hydraulic Systems Engineering

**Integrated Hydraulic Circuit Manifolds
Custom OEM Designs
Featuring **SUN** Hydraulics Floating Cartridge Design**

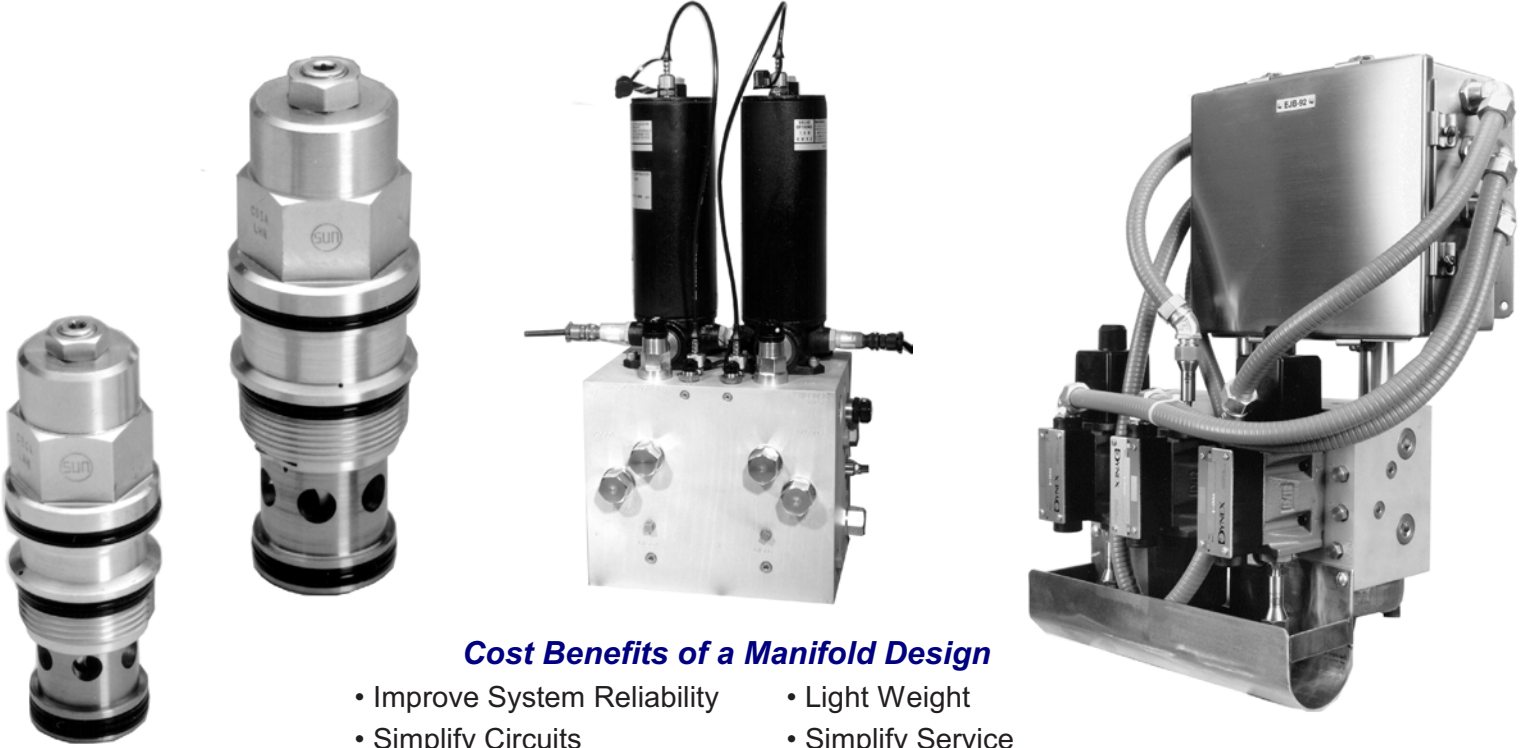

Cost Benefits of a Manifold Design

- Improve System Reliability
- Simplify Circuits
- Reduce Leakage Points
- Reduce Piping Costs
- Save Space
- Light Weight
- Simplify Service
- Reduce Assembly Time
- Reduce Spare Parts Inventory
- Lower Installation Cost

Hydraulic Power Units to Match Any Circuit Requirements

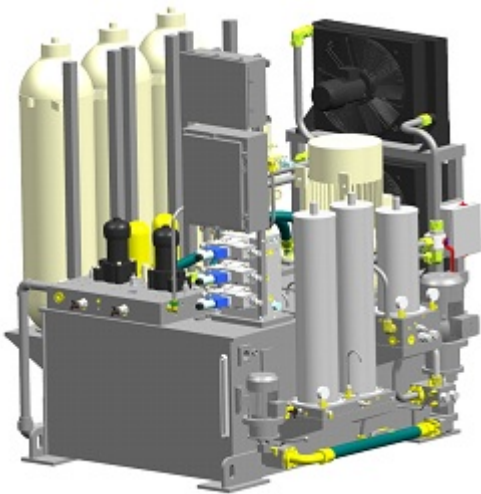

***Rugged Industrial Units
Stainless Steel Construction
For Refinery And
Power Plant Usage***

***Cost Effective & Modular
Flex Power Pack
Hydraulic Systems***

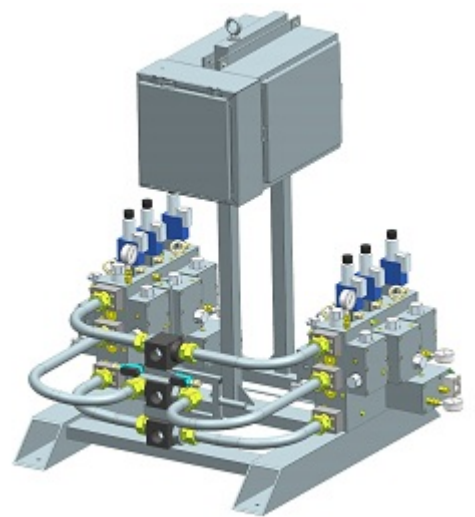
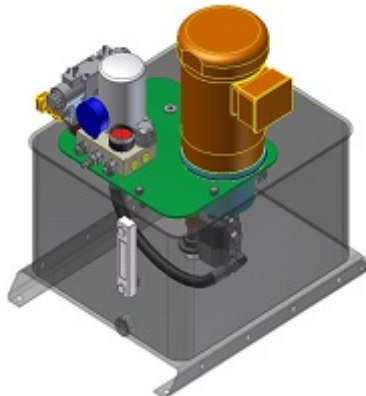

***Units Designed To Meet
Your Most Stringent
Requirements***

OEM Family of Products

1. Featuring SUN Hydraulics Corporation

- Screw-in Cartridges
- (5) Basic Sizes to 400 GPM & 5000 PSI
- Relief and Sequence Valves
- Reducing and Reducing Relieving
- Load Control and Check Valves
- Flow Control Valves and Priority Flow Controls
- Flow Dividers & Combiners
- Solenoid Valves
- Line Mount and Sandwich Bodies
- Custom Design Valve Paks

-
- Atlas, Hanna, & Ortman Cylinders**
Hydraulic, air cylinders and accumulators
NFPA/JIC square head design
Custom design capability
Servo positioning cylinders
 - Haldex/Concentric Hydraulics**
Hydraulic gear pumps and motors
AC/DC pump motor combinations
High performance W Series to 4000 PSI
Modular Hydraulic Power Units
 - Wandfluh**
Miniature spool & poppet style solenoid controls
Pressure & Flow control devices
Proportional valves & Electronic Control Systems
Digital Smart Valves & Controls
NFPA industrial directional valves
Hytos
Gear Pumps & Pressure Controls
NFPA industrial directional valves & Modular HPU's
 - Daman Products Company, Inc.**
Bar manifold parallel and series
D03, D05, D05H and D08 sizes
Custom Manifold Solutions
 - Dynex/Rivett, Inc.**
Custom design hydraulic systems
NFPA - pressure and directional controls
High pressure 10,000 PSI checkball pumps
 - Argo & Hy-Pro**
Hydraulic filters & Filtration Systems
Flows from ¼ GPM to 2,650 GPM
 - Estridge, Inc.**
Hydraulic brakes and planetary gear boxes
SAE mounts 225,000 in/lb rating
Brakes - fail safe multiple disc-spring applied
 - Fluid Power Products, Inc.**
Components, Systems and Engineering:
Technical assistance always available to help with the selection of standard or custom engineered components & systems.
 - FPP (Flex Power Pack)**
Modular power unit systems Series 10/15, 20, 25, & 30
(4) Basic sizes: ½ to 5 HP, 7 ½ to 20 HP & 25 to 30 HP
 - Fulflo Specialties Company, Inc.**
Direct acting relief valves
Cast iron - brass - steel and stainless steel
Sizes from ¼" to 4" NPTF, SAE & ANSI Flange
 - Woodward HR Textron**
Direct drive servo valves
 - ASP Mini Booster & Hydronic**
Hydraulic intensifiers (ASP formerly Iverson & Sherex)
Ratios to 265:1 - Pressures to 26,500 PSI
 - KYB Hydrostar**
Low speed high torque radial piston motors
Multiple speed options available
 - Lexair, Inc.**
Hydraulic and pneumatic control valves
 - Micromatic**
"Rotac" and "Hydroac" rotary actuators
Torque capability to 725,000 in./lbs.
Miniature Robotic Rotary Actuators
 - Nacol - Wilkes & McLean, Ltd. Accumulators, Inc.**
Hydraulic accumulators
Bladder & Piston type - sizes 5 in³ to 40 gallons
Hydraulic noise shock suppressors
 - The Oilgear / Hydura Pump Company**
Axial piston pressure compensated units
Sized from .49 in³ to 22.4 in³/REV
Pumps and motors - fixed and variable
Pressures to 5000 PSI
 - Parker Hannifin Corp. White Drive Products, Inc.**
Geroller & Roller Stator- low speed high torque hydraulic motors - Torklink™ and Nichols series.
 - R & R Transmissions, Inc.**
Planetary gear reducers & Wheel drives
M&S Spool Valve Hydraulic Motors
 - Thermal Transfer Products, Inc.**
Heat exchangers and accessories
High efficiency shell & tube models
Air cooled oil units
 - LDI/Vescor, BSF, & Magnaloy**
Reservoirs, accessories and NEMA-C face pump/motor mounts & couplings
 - Zinga Industries, Inc.**
Low cost suction and return filtration & accessories
Large selection spin-on filters
Pipe, flange and SAE mountings
 - SAI**
Open & Closed Loop Variable Displacement Pumps & Motors, Modular Planetary Gear Boxes
 - Delta Motion**
Multi Axis Closed Loop Servo Control Systems
Position, Velocity, Force, & Synchronous Control
-

Specializing In OEM Components & Hydraulic Systems Engineering

Product Index

See OEM Family of Products (previous page) for Company Reference

- **Accumulators** 2, 17
bladder and piston type
throw away units
- **Brakes** 8,24
fail-safe design
- **Check Valves** 1, 6
check valve cartridges
pilot to open check valves
pilot to close units
- **Cylinders Linear Actuators** 2, 9
NFPA tie rod
mill type
special design
- **Directional Control Valves** 1, 4, 6, 9, 12, 15
solenoid - solenoid pilot
air and oil pilot models
mechanical operators - cam lever, stem control
proportional and servo control
- **Filters** 7, 23
line mounted - manifold models
spin-ons - duplex units
ΔP indicators visual and electronic
- **Flow Control Valves** 1, 4, 6, 9, 12, 19
fixed-variable
pressure bypass types - flow dividers
flow fuses
proportional controls
- **Gear Boxes** 8, 20
planetary gear reducers
wheel drives
- **Heat Exchangers** 9, 21
standard shell & tube
air cooled units
TEMA design capability
- **Electro Hydraulic** 2, 25
servo positioning cylinders
- **Hydrostatic Transmissions** 24
Open & Closed Loop
Drives & Controls
- **Hydraulic Accessories** 1, 9, 22
automatic air bleeds
gage snubbers & fuses
pressure gages
SAE (4) bolt flange C61/62
SAE NEMA C motor mounts
flow meters
- **Hydraulic Intensifiers** 13
- **Hydraulic Motors** 3, 6, 14, 18, 19, 20
low speed - high speed gear, gerotor
and piston unit
radial piston designs
fixed and variable displacement
- **Hydraulic Pumps** 3, 4, 6, 9, 18
gear - fixed clearance
gear - pressure balanced
gerotor (Double AA)
axial piston - valve plate
axial piston - checkball type
variable volume pressure compensated
- **Load Holding Valves** 1
ratios 1:1 - 3:1 - 4.5:1 - 10:1
counterbalance & motor controls
insensitive to back pressure designs
- **Manifolds** 1, 5, 9
integrated hydraulic circuits
custom design
standard bar or special bar units
- **Power Units** 3, 6, 9, 10
miniature
standard modular units
custom fabricated with electrical controls
- **Pressure Control Valves** 1, 6, 9, 11
direct acting and pilot operated
remote control - ventable relief
sequence - unloading
reducing - reducing relieving
proportional control
- **Rotary Actuators** 6, 14, 16
low speed - high torque radial piston
vane type
- **Shock Suppressors** 17
in line - compact design

Also Available From Fluid Power Products:

A comprehensive line of general hydraulic components to assist your company in completing your hydraulic requirements.

Featuring: Anchor SAE Flanges - Heco Planetary Reducers - HSI & Georgia Hydraulic Welded Construction Cylinders - Hedland Flow Meters - Pall Filters - Pressure Gages (all types) - Balluff Transducers - Canfield Connectors - SSI Pressure & Temperature Switches - Tyrone Pumps -

Galland Henning Nopak Cylinders & Accessories

Visit Our Web Site: www.fppinc.com

Specializing In OEM Components & Hydraulic Systems Engineering